

## LIST OF PRODUCTS

- \* Digital Multimeter
- \* AC Clamp Adaptor
- \* Thermo Anemometer
- \* Distance Meter
- \* Network Cable Tester
- \* Earth Resistance Tester
- \* DC Power Supplies
- \* Calibrators
- \* Frequency Counter
- \* Phasing Sticks
- \* Waterproof Pen Testers
- \* EMF Detector
- \* Wood, Paper & Grain Moisture Meter
- \* Transistorised Electronic Analog & Digital Insulation Resistance Testers(upto 15 KV)
- \* Digital Sound Level Meter & Sound Level Calibrator
- \* Digital contact & Non-contact Type Tachometer
- \* Digital Non-contact (infrared) Thermometer/ Thermal Imaging Camera
- \* Maximum Demand Controller/Digital Power Meter
- \* Digital Hand Held Temperature Indicators
- \* Digital AC & AC/DC Clampmeter
- \* AC/DC Current Adaptor
- \* Thermo Hygrometer
- \* Digital Lux Meter
- \* Power Factor Regulator
- \* Digital Panel Meters
- \* High Voltage Detectors
- \* Gas Detectors
- \* Function Generator
- \* Battery Tester
- \* Solar Power Meter
- \* Discharge Rods(400 KV)

**KUSAM-MECO**<sup>®</sup>

Email : [sales@kusam-meco.co.in](mailto:sales@kusam-meco.co.in)

Website : [www.kusamelectrical.com](http://www.kusamelectrical.com)

**KUSAM-MECO**<sup>®</sup>  
AN ISO 9001:2015 COMPANY

## TRMS DIGITAL MULTIMETER MODEL - KM 789

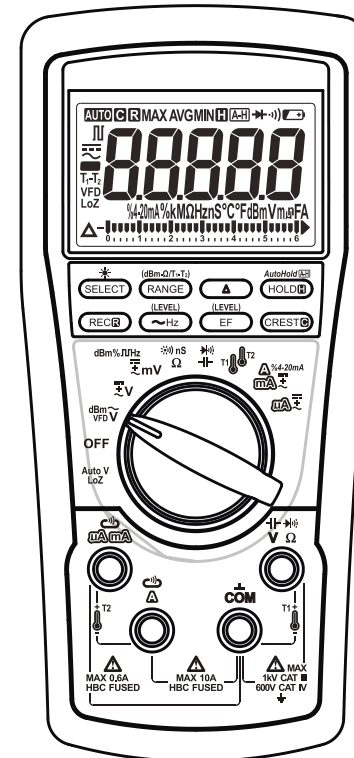

**OPERATION MANUAL**

**WARRANTY**

Each "KUSAM-MECO" product is warranted to be free from defects in material and workmanship under normal use & service. The warranty period is one year (12 months) and begins from the date of despatch of goods. In case any defect occurs in functioning of the instrument, under proper use, within the warranty period, the same will be rectified by us free of charges, provided the to and fro freight charges are borne by you.

This warranty extends only to the original buyer or end-user customer of a "KUSAM-MECO" authorized dealer.

This warranty does not apply for damaged Ic's, fuses, disposable batteries, carrying case, test leads, or to any product which in "KUSAM-MECO's" opinion, has been misused, altered, neglected, contaminated or damaged by accident or abnormal conditions of operation or handling.

"KUSAM-MECO" authorized dealer shall extend this warranty on new and unused products to end-user customers only but have no authority to extend a greater or different warranty on behalf of "KUSAM-MECO".

"KUSAM-MECO's" warranty obligation is limited, at option, free of charge repair, or replacement of a defective product which is returned to a "KUSAM-MECO" authorized service center within the warranty period.

THIS WARRANTY IS BUYER'S SOLE AND EXCLUSIVE REMEDY AND IS IN LIEU OF ALL OTHER WARRANTIES, EXPRESS OR IMPLIED, INCLUDING BUT NOT LIMITED TO ANY IMPLIED WARRANTY OF MERCHANTABILITY OR FITNESS FOR A PARTICULAR PURPOSE.

"KUSAM-MECO" SHALL NOT BE LIABLE FOR ANY SPECIAL, INDIRECT, INCIDENTAL OR CONSEQUENTIAL DAMAGES OR LOSSES, INCLUDING LOSS OF DATA, ARISING FROM ANY CAUSE WHATSOEVER.

All transactions are subject to Mumbai Jurisdiction.

**KUSAM-MECO**

MUMBAI

**TEST CERTIFICATE**  
**TRMS DIGITAL MULTIMETER**

This Test Certificate Warranties that the product has been inspected and tested in accordance with the published specifications.

The instrument has been calibrated by using equipment which has already been calibrated to standards traceable to national standards.

MODEL NO.     **KM 789**    

SERIAL NO.                     

DATE:                     

**ISO 9001:2015  
REGISTERED**



**KUSAM-MECO**

**TAKE MEASUREMENTS CAREFULLY AND YOU'LL SPARE  
YOUR METER AND YOURSELF, SOME PAIN.**

Nearly every electrical engineer has a hand held Multimeter. We sometimes take them for granted, until we damage them or "burn them out". If you incorrectly connect your DMM to a circuit or have the DMM on wrong setting, you damage the meter and possibly hurt yourself. You can also get into trouble if you try to measure the voltage across a charged capacitor.

DMM users frequently burn their meters by trying to measure current the same way as they measure voltage, Remember, you measure voltage across a circuit, and current through a circuit. When you use the current input, your DMM becomes a low impedance circuit element. If you accidentally connect this low impedance path across your circuit, you'll effectively short-circuit it. You can, therefore send high current through your meter and severely damage it. Unless the meter has a fused input, you can even get an explosion or fire.

Even if you correctly insert your DMM into the circuit, you can still damage your meter. Don't try to measure current in excess of your meter's capacity. Handheld DMMs usually have a maximum current rating of 10A or 20A.

If you are measuring current in industrial environment, you can easily exceed those ratings. The best way to avoid damage is to use a clamp meter or to connect a clamp attachment to your DMM.

To prevent excess current from flowing through your meter, always disconnect the test leads from the circuit under test whenever you change DMM functions, Set your meter to the correct function, say current and its highest range for the setting, say 20A.

Next, connect the test leads before you apply power to the circuit. To be safe, start by setting your meter to its highest range first.

**TABLE OF CONTENTS**

TITLE	PAGE
1. SAFETY.....	1
2. INTERNATIONAL ELECTRICAL SYMBOLS.....	3
3. CENELEC DIRECTIVES.....	3
4. SPECIFICATIONS.....	4
GENERAL SPECIFICATIONS.....	4
ELECTRICAL SPECIFICATIONS.....	7
5. PRODUCT DESCRIPTION.....	17
6. OPERATION.....	18
7. MAINTENANCE.....	36
8. TEST CERTIFICATE.....	38
9. WARRANTY.....	39

**Fuse use and replacement**

The Meter uses:

Fuse (F1) for **A** input:

Bussmann DMM-11AR; 11A/1000Vac & Vdc, IR 20kA, F fuse;  
Dimension: 10 x 38mm

Fuse (F2) for **μA/mA** input:

SIBA 7017240; 0.4A/1000Vac & Vdc, IR 30kA, F fuse;  
Dimension: 6 x 32 mm

Turn the rotary knob to OFF position. Loosen 6 captive screws (2 are under the tiltstand) from the bottom housing. Lift the battery compartment cartridge. Further loosen 2 captive screws under the battery compartment cartridge. Lift the upper housing and replace with new fuse(s). Replace the upper housing, and make sure the rotary knob is pointing at the OFF position when doing so. Re-fasten the 2 captive screws under the battery compartment cartridge. Replace the battery compartment cartridge. Re-fasten the 6 captive screws on the bottom housing.

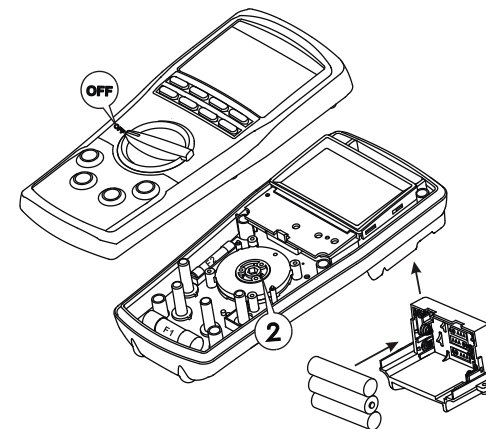

## 7. MAINTENANCE

**Note:** To avoid electrical shock, disconnect the meter from any circuit, remove the test leads from the input jacks and turn OFF the meter before opening the case. Do not operate with open case.

### Trouble Shooting

If the instrument fails to operate, check batteries and test leads etc., and replace as necessary. Double check operating procedure as described in this user's manual. Refer to the LIMITED WARRANTY section for obtaining calibration, repairing or warranty service.

### Accuracy and Calibration

Accuracy is specified for a period of one year after calibration. Periodic calibration at intervals of one year is recommended to maintain meter accuracy.

### Cleaning and Storage

Periodically wipe the meter and the test probe assembly with a damp cloth and mild detergent. Do not use abrasives or solvents. Allow to dry completely before operating. If the meter is not to be used for periods of longer than 30 days, remove the batteries and store them separately.

### Battery use and replacement

The meter uses standard 1.5V AAA Size (IEC R03) battery X 3. Loosen the 2 captive screws on the battery compartment of the bottom housing. Lift the battery compartment cartridge. Replace with new batteries. Replace the battery compartment cartridge. Re-fasten the screws.

## 1. SAFETY

### Terms in this manual

**WARNING** identifies conditions and actions that could result in serious injury or even death to the user.



**CAUTION** identifies conditions and actions that could cause damage or malfunction in the instrument.



This manual contains information and warnings that must be followed for operating the meter safely and maintaining the meter in a safe operating condition. If the meter is used in a manner not specified by the manufacturer, the protection provided by the meter may be impaired.

Observe proper safety precautions when working with voltages above 30 Vrms, 42.4 Vpeak or 60 VDC. These voltage levels pose a potential shock hazard to the user. Do not expose this product to rain or moisture. The meter is intended only for indoor use.

Keep your hands/fingers behind the hand/finger barriers (of the meter and the test probe assembly, where applicable) that indicate the limits of safe access of the handheld parts during measurements. Inspect lead wires, connectors, and probes for damaged insulation or exposed metal periodically. If any defects are found, replace them immediately. Only use the test probe assembly provided with the meter or a UL Listed test probe assembly to the same meter ratings or better.

Optional offer premium test probe assembly using silicone lead wire insulation, at agent's discretion, is equipped with white inner insulation layers as wear indicators. Replace them immediately if any of the white layers has become visible.

Disconnect the test leads from the test points before changing functions.

The meter meets IEC/EN/BSEN/CSA\_C22.2\_No./UL standards of 61010-1 Ed. 3.0, 61010-2-030 Ed. 1.0, 61010-2-033 Ed. 1.0 to Measurement Categories CAT III 1000V and CAT IV 600V ac & dc.

The accompanied test probe assembly meets IEC/EN/BSEN/CSA\_C22.2\_No./UL standards of 61010-031 Ed. 2.0 to the same meter ratings or better. The 61010-031 requires exposed conductive test probe tips to be  $\leq 4\text{mm}$  for CAT III & CAT IV ratings. Refer to the category markings on your probe assemblies as well as on the add-on accessories (like detachable Caps or Alligator Clips), if any, for applicable rating changes.

#### **BRIEF INFORMATION ON MEASUREMENT CATEGORIES**

**Measurement Category IV** is applicable to test and measuring circuits connected at the source of the building's low-voltage MAINS installation. Examples are measurements on devices installed before the main fuse or circuit breaker in the building installation.

**Measurement Category III** is applicable to test and measuring circuits connected to the distribution part of the building's low-voltage MAINS installation. Examples are measurements on distribution boards (including secondary meters), circuit-breakers, cables, bus-bars, junction boxes, switches, socket-outlets, stationary motors in the fixed installation, and equipment for industrial use.

**Measurement Category II** is applicable to test and measuring circuits connected directly to utilization points (socket outlets and

#### **Auto-Power-Off (APO)**

The Auto-Power-off (APO) mode turns the meter off automatically to extend battery life after approximately 30 minutes of no rotary switch or push button operations. To wake up the meter from APO, press the **SELECT** button momentarily and release, or turn the rotary switch OFF and then back on. Always turn the rotary switch to the OFF position when the meter is not in use.

#### **Power-on Options**

##### **• Disabling APO**

Press-and-hold the **SELECT** button while powering on the meter can disable **APO** feature temporarily during the power-on session. The LCD will display "**dSAPO**" to confirm selection before the **SELECT** button is released.

##### **• Disabling beep tone**

Press-and-hold the **RANGE** button while powering on the meter can toggle the beep tone OFF or ON in sequence. The meter confirms selection by displaying "**dSbEP**" for beeper OFF (disabled) or "**EnbEP**" for beeper ON (enabled), before the **RANGE** button is released. Last selection will be saved as power up default. When disabled, most operation beep tones are turned off except those for BeepLit™ Continuity and BeepLit™ Diode functions.

##### **• Shortening APO idling time for inspection**



Press-and-hold the **Δ (Relative)** button while powering on the meter can shorten the **APO** idling time to approximately 8 seconds temporarily during the power-on session. It is designed mainly for production inspection.

##### **• Disabling/Enabling oC or oF function availability**

See Temperature measurement operation description for details.

**Note:** Make sure both test probes are making good contacts simultaneously when using the **AutoHold** feature. Single probe contact may lead to latching floating-signal readings. Removing both probes from the test points simultaneously largely avoids the mis-latching of an unwanted floating-signal.

**MAX/MIN/AVG Record mode**

Press **REC**  button momentarily to activate **MAX/MIN/AVG** recording mode. LCD "**MAX AVG MIN**" turn on. The meter beeps when new **MAX** (maximum) or **MIN** (minimum) reading is updated. Press the button momentarily to read the **MAX, MIN, AVG** and **MAXAVGMIN** (active measurement) readings in sequence. Press **REC**  button for one-second-or-more to exit this mode. Auto-Power-Off is disabled automatically in this mode.

**Relative Δ mode**

**Relative** mode allows the user to offset the meter consecutive measurements with the displaying reading as the reference value. LCD "**Δ**" turns on. Press the **Δ** button momentarily to toggle **Relative Δ** mode.

**CREST mode**











Press **CREST** button momentarily to activate **CREST** mode (Instantaneous PEAKHOLD) to capture current or voltage peak values in duration as short as 0.25ms. LCD **Ⓢ** & **MAX** turn on. The meter beeps when new **Ⓢ MAX** (maximum) or **Ⓢ MIN** (minimum) reading is updated. Press the button momentarily to toggle the **Ⓢ MAX** and **Ⓢ MIN** readings. Press the button for one-second-or-more to exit this mode. Auto-Power-Off is disabled automatically in this mode. Availability: Voltage and Current functions.

**Beep-Jack™ Input Warning**

The meter beeps as well as displays "**InEr**" to warn the user against possible damage to the meter due to improper connections to the **μA, mA, or A** input jacks when another function, especially a voltage function, is selected.

similar points) of the low-voltage MAINS installation. Examples are measurements on MAINS CIRCUITS of household appliances, portable tools and similar equipment.

**2. INTERNATIONAL ELECTRICAL SYMBOLS**

	Marking of Electrical and Electronic Equipment (EEE). Do not dispose of this product as unsorted municipal waste. Contact a qualified recycler
	Caution ! Refer to the explanation in this Manual
	Caution ! Risk of electric shock
	Earth (Ground)
	Double Insulation or Reinforced Insulation
	Fuse
	AC--Alternating Current
	DC--Direct Current
	Three-phase Alternating Current
	Application around and removal from hazardous live conductors is permitted

**3. GENELEC DIRECTIVES**

The instruments conform to (CE) Low-Voltage Directive 2014/35/EU, Electromagnetic Compatibility Directive 2014/30/EU, and RoHS 2 Directive 2011/65/EU plus amendment Directive (EU) 2015/863.

## 4. SPECIFICATIONS :

### GENERAL SPECIFICATIONS :

**Display:** 4-5/6 digits 60,000 counts.

**Polarity:** Automatic

**Update Rate:**

4-5/6 digits: Max 5 per second nominal

31 Segment Bar-graph: 50 per second max

**Operating Temperature:** -20°C to 55°C continuous operating (except on **A** function, see Electrical Specifications below for more details)

**Relative Humidity:** Maximum relative humidity 80% for temperature up to 31°C decreasing linearly to 50% relative humidity at 55°C

**Pollution degree:** 2

**Storage Temperature:** -20°C to 60°C, < 80% R.H. (with battery removed)

**Altitude:** Operating below 2000m

**Temperature Coefficient:** nominal 0.10 x (specified accuracy)/ °C @ (-20°C ~ 18°C or 28°C ~ 55°C), or otherwise specified

**Sensing:** AC and AC+DC True RMS

**Safety:** Double insulation per IEC/UL/EN/BSEN 61010-1 Ed. 3.0, IEC/UL/EN/BSEN 61010-2-030 Ed. 1.0, IEC/UL/EN/BSEN 61010-2-033 Ed. 1.0, IEC/UL/EN/BSEN 61010-031 Ed.2.0 and the corresponding CAN/CSA-C22.2 regulations to Measurement Categories III 1000V AC & DC and Category IV 600V AC & DC

### **HOLD**

**HOLD** feature freezes the display for later view. LCD “**H**” turns on. Press the **HOLD** button momentarily to toggle the **HOLD** feature.

### **AutoHold Real-Read™ **A-H****

**AutoHold** feature displays the last latched stable-reading for later view when the test leads are removed from the test points after a significant-measurement session. Real-Read™ is to show real-time readings during the significant-measurement session to avoid “blind” measurements. Press the **AutoHold **A-H**** button for one-second-or-more to toggle the **AutoHold** feature on. LCD “**A-H**” turns on. Availability: Resistance, Continuity, LoZ AutoV, VFD Volts, Voltage and Current functions.

- Significant-measurements (readings) are >5% of range in Voltage and Current functions, or non-OL in Resistance function.
- Stable-reading is a significant-measurement reading having ≤ 30 counts in difference with its two immediate preceding measurement readings.
- Significant-measurement readings are being displayed in real time (Real-Read™); “- - - -” is being displayed while awaiting significant-measurements.
- The **AutoHold** gives a short-beep with a flashing “**A-H**” when a stable-reading is successfully latched ready for later display. If any of the further significant-measurement readings differs from the latched reading by >30 counts, the latched-reading will be reset waiting to re-latch a new stable-reading.
- After a significant-measurement session, **AutoHold** gives a short-beep and displays the latched-reading. The reading flashes to emphasize it is on hold to avoid confusions.
- The **AutoHold** gives 3 short-beeps and “- - - -” flashes to indicate a null capture after a significant-measurement. It represents no stable-reading is being latched or that has been reset after further encountering unstable signal changes to avoid displaying misleading readings.



**KUSAM-MECO**

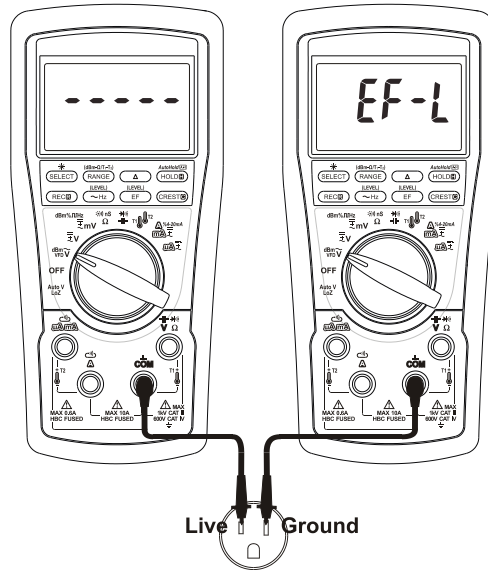

#### LCD Backlight

Press the **SELECT** button for one-second-or-more to toggle the LCD backlight. The LCD backlight goes off automatically after idling for approximately 16 minutes to extend battery life.

#### Manual or Auto-ranging

For most auto-ranging functions (LCD "**AUTO**" turns on by default), press the **RANGE** button momentarily to override and select manual-ranging. The meter will remain in the range it was in, the LCD "**AUTO**" turns off. Press the button momentarily again to select the next range. Press **RANGE** button for one-second-or-more to resume auto-ranging.

**Note:** Manual-ranging feature is not available to the **Auto-V**, **dBm**, **Capacitance** & **Hz** functions.

**KUSAM-MECO**

#### Overload Protections:

$\mu$ A & mA: 0.4A/1000V DC/AC, IR 30kA or better, F fuse

A: 11A/1000V DC/AC, IR 20kA or better, F fuse

V: 1100V DC/AC rms

mV,  $\Omega$  & Others: 1000 V DC/AC rms

**Transient protection:** 8kV (1.2/50 $\mu$ s surge)

**E.M.C.:** Meets EN/BSEN 61326-1:2013

**Power Consumption:** 10mA typical for AC & AC+DC

Voltage/Current functions; 8mA

typical for other functions

**Low Battery:** Below approx. 3.7V

**APO Timing:** Idle for 15 minutes

**APO Consumption:** 15 $\mu$ A typical.

**Power Supply:** Standard 1.5V AAA Alkaline battery x 3

**Weight:** Approx. 420 gm

**Dimension:** Approx. 193(L) X 89(W) X 51(H)mm

**Accessories:** Test lead pair, User's manual, Bkp60 banana plug

K-type thermocouple x 1

**Optional Accessories:** BKB32 banana plug to type-K socket plug adaptor, BMH-02 magnetic hanger strap

**Special Features:**

- Record MAX, MIN, & AVG readings
- Crest (Instantaneous Peak hold)
- MAX & MIN readings
- Relative Zero mode
- Data Hold
- Backlighted LCD display
- BeepJack™ audible & visible input warning
- %4-20mA loop current readings
- T1-T2 differential temperature readings
- dBm readings
- AutoHold
- VFD
- BeepLit™ Continuity

**EF-Detection of Electric Field**

Press **EF** button momentarily to enter **EF-Detection** function. Defaults at high sensitivity **EF-H**. The meter displays “**EF-H**” when it is ready. If it is too sensitive for your applications, press **EF** button momentarily to select lower sensitivity “**EF-L**”. The detected Electric Field strength is indicated as a series of bar-graph segments on the display plus variable beep tones. Press **EF** button for one-second-or-more to exit **EF-Detection** function.

■ **Non-Contact EF-Detection (NCV):**

An antenna is located along the top-right corner which detects the electric field surrounding energized conductors. It is ideal for tracing live wiring connections, locating wiring breakages and to distinguish between live and earth connections.

■ **Probe-Contact EF-Detection (Single-pole):**

For more precise indication of live wires, such as distinguishing between Live and Ground connections, use one single test-probe to test via terminal **COM** for direct metal contact probing to achieve the most distinctive indications.

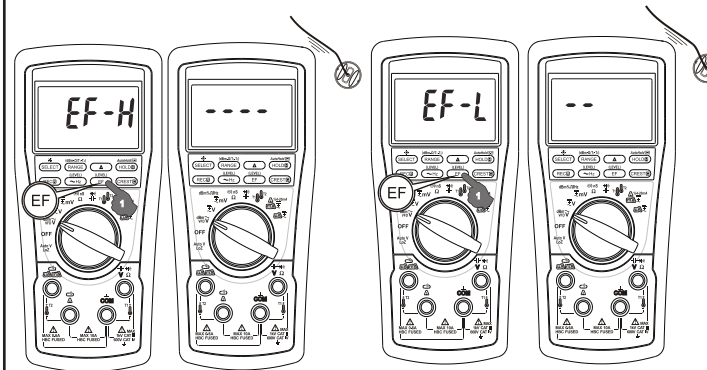

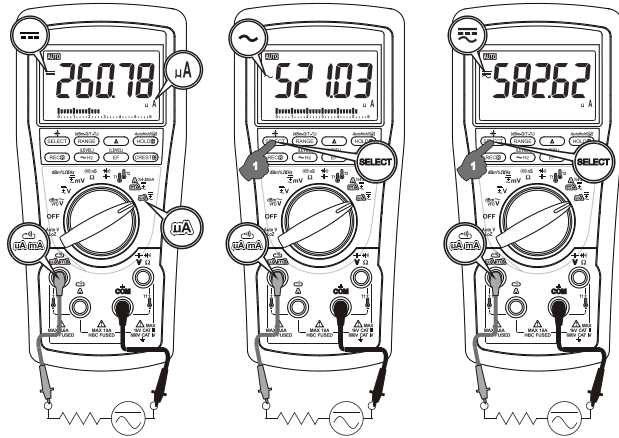

**mA Current**

Inputs are made via the input terminals **uA mA -COM**. Press the **SELECT** button momentarily to select **DC, AC, DC+AC** and **%4-20mA** in sequence. Last selection will be saved as power up default for repeat measurement convenience of all current functions.

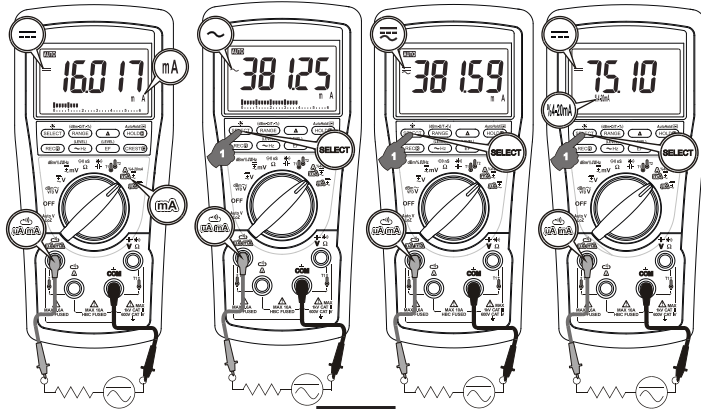

**ELECTRICAL SPECIFICATIONS :**

Accuracy is  $\pm(\%$  reading digits + number of digits) or otherwise specified, at  $23^{\circ}\text{C} \pm 5^{\circ}\text{C}$  & less than 75% relative humidity. Maximum Crest Factor <1.6:1 at full scale & < 3.2:1 at half scale, and with frequency components fall within the specified frequency bandwidth for non-sinusoidal waveforms.

**DC VOLTAGE**

RANGE	ACCURACY
600.00mV, 6.0000V, 60.000V	0.03% + 2d
600.00V	0.05% + 5d
1000.0V	0.15% + 5d

Input Impedance: 10M $\Omega$ , 75pF nominal (280pF nominal for 600mV range)

**AC VOLTAGE**

RANGE	ACCURACY <sup>1)</sup>
<b>50Hz ~ 60Hz</b>	
600.00mV <sup>2)</sup> , 6.0000V, 60.000V, 600.00V, 1000.0V	0.5% + 30d
<b>40Hz ~ 1kHz</b>	
600.00mV <sup>2)</sup> , 6.0000V, 60.000V, 600.00V, 1000.0V	0.9% + 30d
<b>1kHz ~ 7kHz</b>	
600.00mV <sup>2)</sup> , 6.0000V, 60.000V, 600.00V	1.8% + 40d
1000.0V	Unspec'd
<b>7kHz ~ 20kHz</b>	
600.00mV <sup>2)</sup> , 6.0000V, 60.000V, 600.00V <sup>3)</sup>	2.0% + 60d
1000.0V	Unspec'd
<b>20kHz ~ 100kHz</b>	
600.00mV <sup>2)4)</sup> , 6.0000V <sup>4)</sup> , 60.000V <sup>4)</sup>	4.0% + 60d
600.00V, 1000.0V	Unspec'd

- 1)Accuracy specified from 10% to 100% of range
  - 2)Signal peak absolute values, including DC bias, less than 1000mVpeak
  - 3)Bandwidth specified to 10kHz only for 600V range
  - 4)Accuracy specified from 30% to 100% of range
- Input Impedance: 10MΩ, 75pF nominal (140pF nominal for 600mV range)  
Residual reading less than 50 digits with test leads shorted

**AC+DC VOLTAGE**

RANGE	ACCURACY <sup>1)</sup>
<b>50Hz ~ 60Hz</b>	
600.00mV <sup>2)</sup> , 6.0000V, 60.000V, 600.00V, 1000.0V	0.7% + 40d
<b>0Hz, 40Hz ~ 1kHz</b>	
600.00mV <sup>2)</sup> , 6.0000V, 60.000V, 600.00V, 1000.0V	1.2% + 40d
<b>1kHz ~ 7kHz</b>	
600.00mV <sup>2)</sup> , 6.0000V, 60.000V, 600.00V	2.0% + 50d
1000.0V	Unspec'd
<b>7kHz ~ 20kHz</b>	
600.00mV <sup>2)</sup> , 6.0000V, 60.000V, 600.00V <sup>3)</sup>	2.5% + 70d
1000.0V	Unspec'd

- 1)Accuracy specified from 10% to 100% of range
  - 2)Signal peak absolute values, including DC bias, less than 1000mVpeak
  - 3)Bandwidth specified to 10kHz only for 600V range
- Input Impedance: 10MΩ, 75pF nominal (140pF nominal for 600mV range)Residual reading less than 50 digits with test leads shorted.

**A Current**

Inputs are made via the input terminals **Δ**-COM. Press the **SELECT** button momentarily to select **DC, AC, DC+AC** in sequence. Last selection will be saved as power up default for repeat measurement convenience of all current functions.

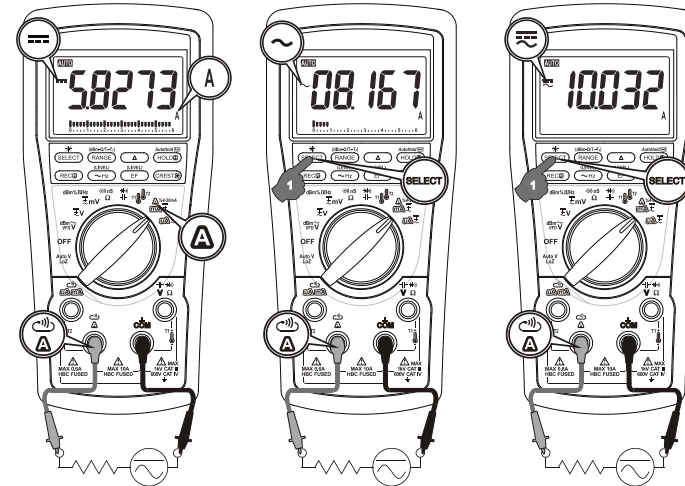

**μA Current**

Inputs are made via the input terminals **uA mA**-COM. Press the **SELECT** button momentarily to select **DC, AC, DC+AC** in sequence. Last selection will be saved as power up default for repeat measurement convenience of all current functions.

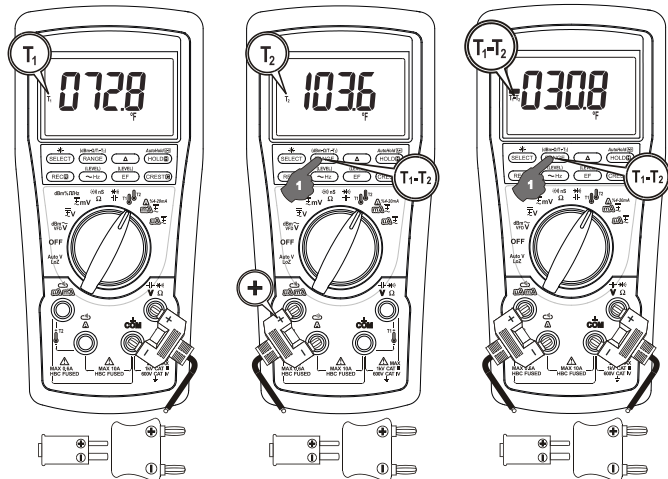
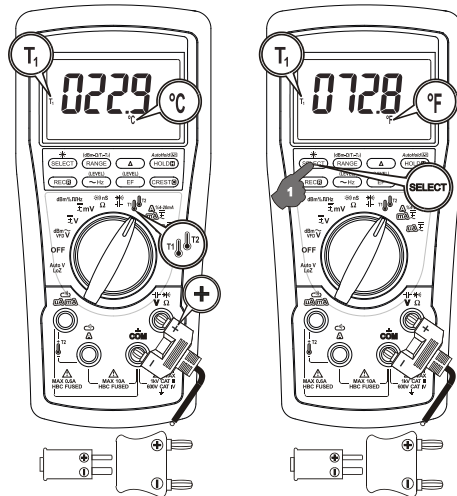

**VFD AC VOLTAGE**

RANGE	ACCURACY <sup>1)</sup>
<b>10Hz ~ 200Hz</b>	
600.00V, 1000.0V	4% + 50d
<b>200Hz ~ 440Hz</b>	
600.00V, 1000.0V	10% + 50d <sup>2)</sup>

- 1) Signal fundamental frequency > 440Hz is unspecified
- 2) Accuracy linearly decreases from 2% + 50d @ 200Hz to 10% + 50d @ 440Hz

**LoZ Auto-DCV**

RANGE	ACCURACY
6.0000V, 60.000V, 600.00V, 1000.0V	0.5% + 30d

LoZ Auto-DCV Threshold: > +1.0VDC or < -1.0VDC nominal  
 LoZ Auto-DCV Input Impedance:  
 Initially approx. 2.1kΩ, 140pF nominal; Impedance increases abruptly within a fraction of a second as display voltage is above 50V (typical). Ended up impedances vs display voltages typically are:

- 12kΩ @ 100V
- 90kΩ @ 300V
- 300kΩ @ 600V
- 670kΩ @ 1000V

**LoZ Auto-ACV**

RANGE	ACCURACY <sup>1)</sup>
<b>50Hz ~ 60Hz</b>	
6.0000V, 60.000V, 600.00V, 1000.0V	1.0% + 40d

1)Accuracy specified from 10% to 100% of range  
 LoZ Auto-ACV Threshold: > 1.0VAC (50/60Hz) nominal  
 LoZ Auto-ACV Input Impedance:  
 Initially approx. 2.1kΩ, 140pF nominal; Impedance increases abruptly within a fraction of a second as display voltage is above 50V (typical). Ended up impedances vs display voltages typically are:

- 12kΩ @ 100V
- 90kΩ @ 300V
- 300kΩ @ 600V
- 670kΩ @ 1000V

**dBm**

Range and accuracy are subject to ACmV, ACV and reference impedance selected.  
 Typical 600Ω reference impedance ranges:  
 In ACmV: -42.22 dBm to -2.22 dBm  
 In ACV: -17.78 dBm to 62.22 dBm  
 Input Impedance: 10MΩ, 140pF nominal  
 Selectable reference impedance of 4, 8, 16, 32, 50, 75, 93, 110, 125, 135, 150, 200, 250, 300, 500, 600, 800, 900, 1000 and 1200Ω

■ **Enabling °F and/or °C readings**

**1) Enabling both °F and °C readings :**

Press-and-hold **EF** button to power on the meter. The meter displays “**C-F**” to acknowledge both °F and °C readings are enabled.

**2)Enabling °C readings only:**

Repeat step #1 when needed. Turn on the meter to temperature function. Select readings in °**C** and then turn the meter off. Press -and-hold **CREST** button to power on the meter again. The meter displays “**C**” to acknowledge °C readings only is enabled.

**3) Enabling °F readings only:**

Repeat step #1 when needed. Turn on the meter to temperature function. Select readings in °**F** and then turn the meter off. Press -and-hold **CREST** button to power on the meter again. The meter displays “**F**” to acknowledge °F readings only is enabled.

**Note:**

- 1)Temperature accuracies assume meter interior has the same temperature (isothermal stage) of the ambient for a correct junction voltage compensation. Allow the meter and the type-K probe set to reach isothermal stage for a significant change of ambient temperature. It can take up to an hour for changes > 5°C.
- 2) Beware +/- polarities of the banana-plug when using the type -K temperature bead probe Bkp60.
- 3) Banana-pins to type-K socket adapter Bkb32 (Optional purchase) can be used to adapt other type-K probes with standard miniature plugs. However, the adapter becomes part of the measurement isothermal block when in use, and should be included in the overall isothermal considerations to minimize erratic readings.

■ **BeepLit™ Diode**

● **Reading indication:** Forward voltage drop (forward biased) for a good silicon diode is between 0.400V to 0.900V. A higher reading indicates a leaky diode (defective). A zero reading indicates a shorted diode (defective). An over-range display indicates an open diode (defective). Reverse the test leads connections (reverse biased) across the diode. The digital display shows over-range if the diode is good. Any other readings indicate the diode is resistive or shorted (defective).

● **Beep-Alert & BeepLit™ indication:**

When the display reading drops across 0.850V, the meter alerts a short beep to signal a reasonable forward voltage drop of common diodes. However, if the reading further drops below 0.100V, the meter gives a continuous beep tone together with flashing display backlight to indicate a shorted diode or a complete wire. It is similar to that of BeepLit™ Continuity function but BeepLit™ Diode, instead, is based on voltage threshold to indicate a complete wire.

**Note:**

- 1) Discharge capacitor(s) before making capacitance measurements. Large value capacitors should be discharged through an appropriate resistance load.
- 2) Using BeepLit™ Diode or Capacitance function in a live circuit will produce false results and may damage the meter. In many cases, the suspected component(s) must be disconnected from the circuit to obtain an accurate measurement reading.

**Temperature T1 & T2**

T1 inputs are made via the input terminals **V-COM**. Press **SELECT** button momentarily can toggle between °C (Celsius) and °F (Fahrenheit) readings when enabled. Last selection will be saved as power up default for repeat measurement convenience. Additional T2 inputs are made via the input terminals **Ω/MA/Δ**. Press **RANGE (T1-T2)** button momentarily to select T1, T2 and T1-T2 in sequence.

**Ohms & Conductance**

RANGE	ACCURACY <sup>1)</sup>
600.00Ω	0.085% + 10d
6.0000kΩ, 60.000kΩ	0.085% + 4d
600.00kΩ	0.15% + 4d
6.0000MΩ <sup>2)</sup>	1.5% + 5d
60.000MΩ <sup>3)4)</sup>	2.0% + 5d
99.99nS <sup>3)5)</sup>	1.0% + 10d

- Open Circuit Voltage: < 1.3VDC (< 1.5VDC for 600Ω range)
- 1) Temperature Coefficient: 0.20 x (specified accuracy) / °C @ (-20°C ~ 18°C or 28°C ~ 55°C)
  - 2) Constant Test Current: 0.1μA Typical
  - 3) Constant Test Current: 0.01μA Typical
  - 4) Specified accuracy adds 0.5% @ >50MΩ
  - 5) Specified accuracy adds 30d @ <10nS

**BeepLit™ Continuity Tester**

Audible threshold: between 100Ω and 420Ω  
 Response time < 100μs  
 Audible Indication: Beep Sound  
 Visible Response: LCD Backlight

**BeepLit™ Diode Tester**

RANGE	ACCURACY	Test Current (Typical)	Open Circuit Voltage
3.0000V	1% + 20d	0.35mA	< 3.1 VDC

Short-Beep-Alert Threshold: Drop Across 0.850V  
 BeepLit™ continuous ON Threshold: < 0.100V  
 Audible Indication: Beep Sound  
 Visible Indication: LCD Backlight

**Capacitance**

RANGE	ACCURACY <sup>1)2)</sup>
10.00nF	1.0% + 10d
100.0nF~1000nF	1.0% + 2d
10.00μF~1.000mF	1.8% + 4d
10.00mF	2.0% + 4d

1)Accuracies with film capacitor or better

2)Temperature Coefficient: 0.20 x (specified accuracy)/ °C @ (-20°C ~ 18°C or 28°C ~55°C)

**DC Current**

RANGE	ACCURACY	Burden Voltage
600.00μA <sup>1)2)</sup>	0.075%+20d	0.2mV/μA
6000.0μA		
60.000mA <sup>2)</sup>	0.15% + 20d	2.0mV/mA
600.00mA		
6.0000A	0.3% + 20d	30mV/A
10.000A <sup>3)</sup>	0.3% + 30d	

1)Specified with Open-circuit-voltage (OCV) of Current-loop-under-test at >100μV.

2)The meter shows a few negative residue counts when the input is short-circuited, with OCV at zero volt. It is the nature of the internal protection circuitry design, and will not affect measurement readings at nominal OCVs greater than 100μV in significant measurements.

3)10A continuous up to ambient 40°C only, and is <3 mins on per >15 mins off @ 40oC ~ 55°C; >10A to 20A for <30 seconds on per >15 mins off.

**■ nS Conductance**

nS Conductance is the inverse of Resistance. That is,  $S=1/\Omega$  or  $nS=1/G\Omega$ . It virtually extends the Resistance measurements to the order of Giga-Ohms for leakage measurements.

**Note:** Using **Resistance, BeepLit™ Continuity or nS Conductance** function in a live circuit will produce false results and may damage the meter. In many cases, the suspected component(s) must be disconnected from the circuit to obtain an accurate measurement reading.

**⚡ Capacitance; 🔊 BeepLit™ Diode**

Inputs are made via the test lead terminals **V-COM**. Press the **SELECT** button momentarily to select the subject functions in sequence. Last selection will be saved as power up default for repeat measurement convenience.

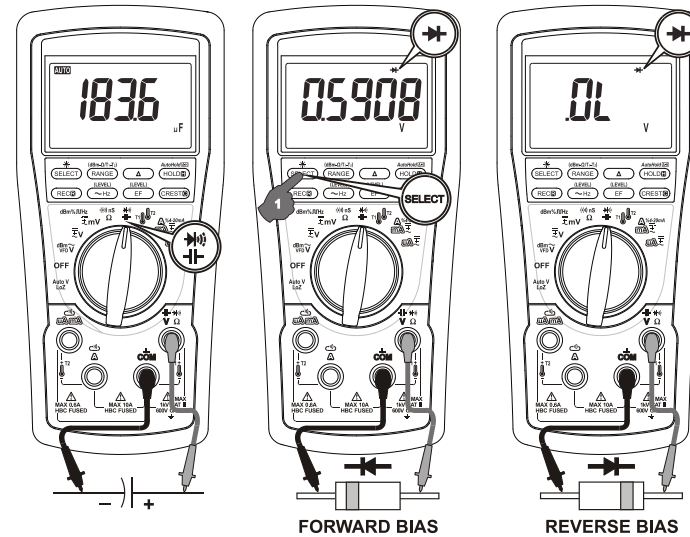



**Note:** In dBm function, power up default reference impedance will be displayed for 1 second before displaying the dBm readings. Press **dBm-Ω (RANGE)** button momentarily to select different reference impedance of 4, 8, 16, 32, 50, 75, 93, 110, 125, 135, 150, 200, 250, 300, 500, 600, 800, 900, 1000, up to 1200Ω. Last selection will be saved as power up default for repeat measurement convenience.

**Ω Resistance; 📡) BeepLit™ Continuity; nS Conductance** Inputs are made via the test lead terminals **V-COM**. Press the **SELECT** button momentarily to select the subject functions in sequence. Last selection will be saved as power up default for repeat measurement convenience.

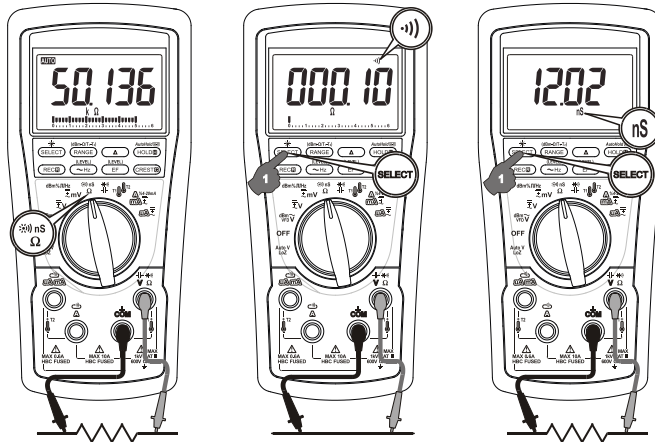

■ 📡) **BeepLit™ Continuity**

This function is having improved convenience for checking wiring connections and operation of switches. Resistance threshold is being used. A continuous beep tone together with display backlight flashing indicate a complete wire. Such audible and visible indications improve continuity readabilities in noisy working environments.

**AC Current**

RANGE	ACCURACY <sup>1)</sup>	Burden Voltage
<b>40Hz ~3kHz</b>		
600.00μA	0.9%+20d	0.2mV/μA
6000.0mA		
60.000mA		
6.0000A	1.0% + 30d	30mV/A
10.000A <sup>2)</sup>		

1)Accuracy unspecified @ <10% of range

2)10A continuous up to ambient 40°C only, and is <3 mins on per >15 mins off @ 40°C ~55°C; >10A to 20A for <30 seconds on per >15 mins off.

**AC + DC Current**

RANGE	ACCURACY <sup>1)</sup>	Burden Voltage
<b>0Hz, 40Hz ~3kHz</b>		
600.00μA	1.0%+30d	0.2mV/μA
6000.0mA		
60.000mA		
6.0000A	1.2% + 40d	30mV/A
10.000A <sup>2)</sup>		

1)Accuracy unspecified @ <10% of range

2)10A continuous up to ambient 40°C only, and is <3 mins on per >15 mins off @ 40°C ~ 55°C; >10A to 20A for <30 seconds on per >15 mins off

**DC Loop Current %4~20mA**

**4mA : 0% (zero)    20mA : 100% (span)**

**Resolution: 0.01%    Accuracy: ± 25d**

**Temperature**

RANGE	ACCURACY <sup>1)2)</sup>
-200.0°C to 1090°C	1.0% + 1.0°C
-328.0°F to 1994°F	1.0% + 1.8°F

- 1) Accuracies assume meter interior has the same temperature (isothermal stage) of the ambient for a correct junction voltage compensation. Allow the meter and the type-K probe set to reach isothermal stage for a significant change of ambient temperature. It can take up to an hour for changes > 5°C.
- 2) Type-K thermocouple range & accuracy not included

**Hz Logic Level Frequency**

RANGE	ACCURACY <sup>1)2)</sup>
5.000Hz ~ 1.0000MHz	0.002%+4d

- 1) Sensitivity: >3.0Vp square wave
- 2) Specified with Pulse Width > 0.5µs

**%Duty Cycle**

5V Logic Frequency	RANGE Specified	Accuracy
5Hz ~ 1kHz	0.10% ~ 99.99%	3d/kHz+2d
1kHz ~ 10kHz	1.00% ~ 99.00%	
10kHz ~ 500kHz	20.00% ~ 80.00%	

Sensitivity: >3.0Vp square wave

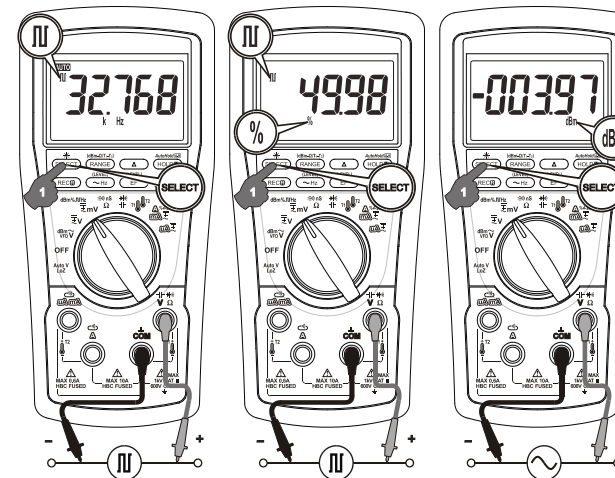
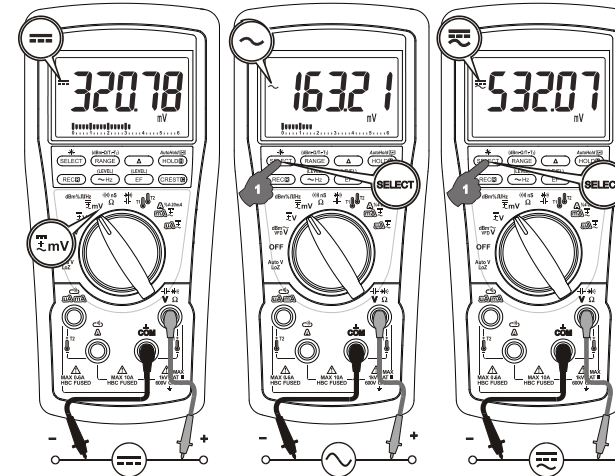

**KUSAM-MECO**

**DCmV; ACmV; DC+ACmV; Logic-level Hz;  
Logic-level Duty %; dBm**

Inputs are made via the test lead terminals **V-COM**. Press the **SELECT** button momentarily to select the subject functions in sequence. Last selection will be saved as power up default for repeat measurement convenience.

-22-

**KUSAM-MECO**

~ Hz Line Level Frequency

Function	RANGE	Sensitivity (Sine RMS)	Range
6V		0.4V	10Hz ~ 50kHz
60V		4V	10Hz ~ 50kHz
600V		40V	10Hz ~ 30kHz
1000V		400V	10Hz ~ 5kHz
VFD 600V		40V	10Hz ~ 400Hz
VFD 1000V		400V	10Hz ~ 400Hz
600μA		40μA	10Hz ~ 5kHz
6000μA		400μA	10Hz ~ 5kHz
60mA		4mA	10Hz ~ 5kHz
600mA		40mA	10Hz ~ 5kHz
6A		0.6A	10Hz ~ 3kHz
10A		6A	10Hz ~ 3kHz

Accuracy: 0.05%+5d

**Non-Contact EF-Detection (NCV)**

Bar-Graph Indication	EF-H (Hi Sensitivity)	EF-L (Lo Sensitivity)
	Typical Voltage (Tolerance)	
-	25V ( 18V ~ 45V)	60V (50V ~ 140V)
--	50V ( 30V ~ 80V)	120V (100V ~ 260V)
---	80V ( 70V ~ 160V)	230V (180V ~ 400V)
----	120V (110V ~ 250V)	400V (330V ~ 490V)
-----	350V (> 270V)	600V (> 500V)

Indication: Bar-graph segments & audible beep tones proportional to the field strength  
 Detection Frequency: 50/60Hz  
 Detection Antenna: Top-left end of the meter

-15-

**Probe-Contact EF-Detection (Single-pole):** For more precise indication of live wires, such as distinguishing between live and ground connections, use one single test probe to test via terminal COM for direct metal contact probing to achieve the most distinctive indications.

**RECORD mode (MAX MIN AVG)**

Function Mode Where Available	Added Uncertainty <sup>1)</sup> to Specified Accuracy	Min. Volts/ Amps Signal Duration	REC Nominal Update Rate per Second
DC	±30d	300ms	10
AC	±300d(±80d <sup>2)</sup> )	460ms	5(10)
VFD	±180d	800ms	5
AC+DC	±300d <sup>2)</sup>	2s	1
nS	--	--	1
Cx	--	--	Subject to Cx Values
Hz, T1-T2	--	--	2
Ω ,T1,T2, Other	--	--	5

- 1) Specified at Range Locked (Manual-ranging)
- 2) Specified at AC Inputs >15% of Range.

**CREST mode (Instantaneous Peak Hold)**

**Accuracy:** Specified accuracy ± 100 digits for changes > 0.35ms in duration

**Availability:** Voltage and Current functions

**Resolution:** 6000 counts

**AutoHold Real-Read™**

**Accuracy:** Specified accuracy ± 50 digits

**Availability:** Resistance, Continuity, LoZ AutoV, VFD Volts, Voltage and Current functions

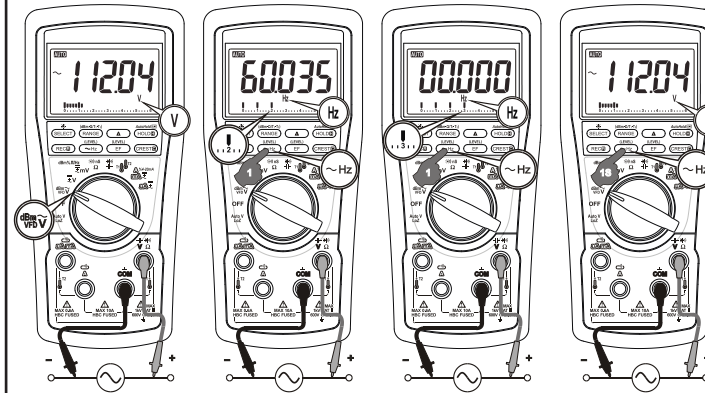

**Note:**

It is recommended to direct measure the signals (voltage or current) in auto-ranging mode before activating the ~Hz function right in that range to get the most appropriate trigger level automatically. If the ~Hz reading is unstable, select lower sensitivity to avoid possible electrical noises. If the reading shows zero, select higher sensitivity to measure.

**DCV; DC+ACV**

Inputs are made via the test lead terminals V-COM. Press the SELECT button momentarily to select the subject functions in sequence. Last selection will be saved as power up default for repeat measurement convenience.

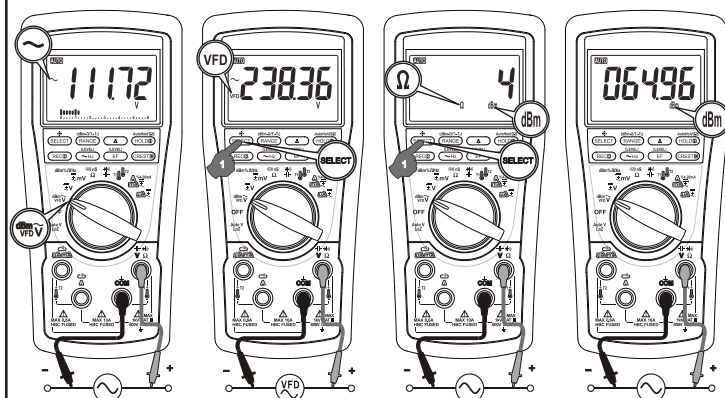

**Note:**

In **dBm** function, power up default reference impedance will be displayed for 1 second before displaying the dBm readings. Press **dBm-Ω (RANGE)** button momentarily to select different reference impedance of 4, 8, 16, 32, 50, 75, 93, 110, 125, 135, 150, 200, 250, 300, 500, 600, 800, 900, 1000, up to 1200Ω. Last selection will be saved as power up default for repeat measurement convenience.

**~Hz Line Frequency**

Press the **~Hz** button momentarily to switch to Line Frequency function. It is only available to the functions as in the table below. Input sensitivity varies automatically with the function range selected while the **~Hz** function is being activated. Level 0 is the highest sensitivity while LEVEL 3 is the lowest. Press momentarily the **~Hz (LEVEL)** button can manually select the available Trigger Levels (see table below) in sequence. Press the **~Hz** button for one-second-or-more to leave Line Frequency function.

TRIGGER	ACV/dBm/DCV/AC+DCV	VFD-ACV	μA	mA	A
LEVEL 0	6V		600 μA	60mA	6A
LEVEL 1	60V		6000 μA	600mA	10A
LEVEL 2	600V	600V			
LEVEL 3	1000V	1000V			

**5. PRODUCT DESCRIPTION**

This user's manual uses only representative model(s) for illustrations. Please refer detailed specifications for function availability to each model.

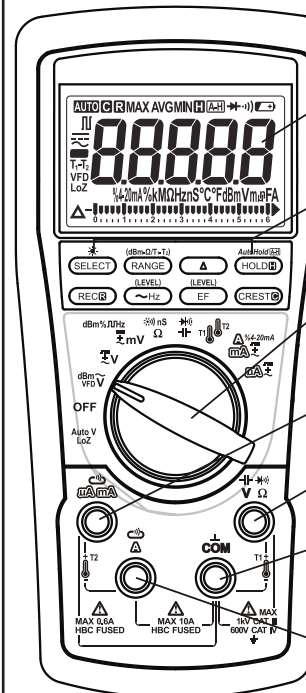

1) 4-5/6 digits 60000 counts display

2) Push-buttons for special functions & features

3) Selector to turn the Power On or Off and Select a function

4) Positive Input Jack for T2 and mA/μA functions

5) Positive Input Jack for all functions EXCEPT T2, A and μA/mA

6) Common/ Negative (Ground reference) Input Jack for all functions EXCEPT T2

7) Positive Input Jack for A function while Negative for T2

**Analog bar-graph**

The analog bar graph provides a visual indication of measurement like a traditional analog meter needle. It is excellent in detecting faulty contacts, identifying potentiometer clicks, and indicating signal spikes during adjustments.

**6. OPERATION**

Note: Before and after hazardous voltage measurements, test the voltage function on a known source such as line voltage to determine proper meter functioning.

**AutoV (LoZ)**

Inputs are made via the test lead terminals V-COM. AutoV automatically selects measurement function of DCV or ACV based on their input levels via the test leads. The input also provides a low ramp-up impedance (LoZ) to drain ghost voltages.

- With no input, the meter displays “Auto” when it is ready.
- When a signal above the voltage threshold of 1V DC or AC up to the rated 1000V is present, the meter displays the voltage value in appropriate DC or AC, whichever larger in peak magnitude.
- Push-button features of only HOLD, AutoHold, EF and Backlight are available in AutoV mode.

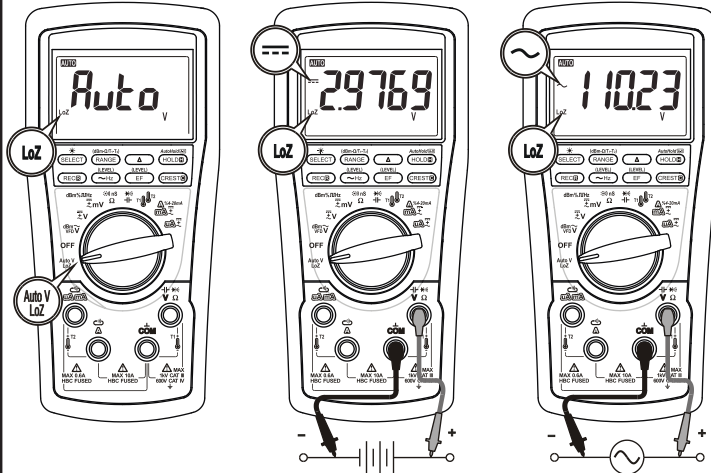

**Note:**

- 1) **Ghost-voltage Buster:** Ghost-voltages are unwanted stray signals coupled from adjacent hard signals, which confuse common multimeter voltage measurements. The AutoV mode provides low (ramp-up) input impedance (approx. 2.1kΩ at low voltage) to drain ghost voltages leaving mainly hard signal values on meter readings. It is an invaluable feature for precise indication of hard signals, such as distinguishing between hot and open wires (to ground) in electrical installation applications.
- 2) **AutoV Mode** input impedance increases abruptly from initial 2.1kΩ to a few hundred kΩ's on high voltage hard signals. “LoZ” displays on the LCD to remind the users of being in such a low impedance mode. Peak initial load current, while probing 1000VAC for example, can be up to 673mA ( $1000V \times 1.414 / 2.1k\Omega$ ), decreasing abruptly to approx. 2.1mA ( $1000V \times 1.414 / 670k\Omega$ ) within a fraction of a second. Do not use AutoV mode on circuits that could be damaged by such low input impedance. Instead, use rotary selector  $\tilde{V}$  or  $\bar{V}$  high input impedance voltage modes to minimize the test loadings for such circuits.

**ACV; VFD-ACV; dBm**

Inputs are made via the test lead terminals V-COM. Press the SELECT button momentarily to select the subject functions in sequence. Last selection will be saved as power up default for repeat measurement convenience.